

THORN

96239818 CONNECT MRE DUC MWMR

		Contents
Section	Contents	Page
1	Dimensional information	1
2	Description and operation	2
3	Fixing and wiring	3
4	Programming	6
5	Detection pattern diagrams	11
6	Fault finding	11
7	Specification	12
8	Part numbers	12

1. Dimensions

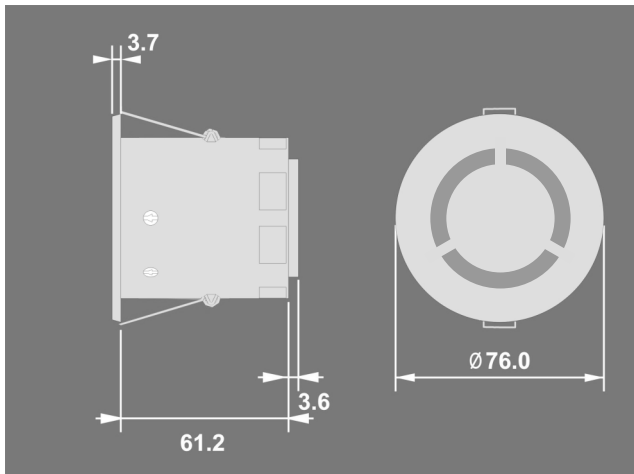

2. Description & Operation

The CONNECT MRE DUC MWMR microwave presence detector switches are designed to provide automatic control of lighting loads via the Connect marshalling box. The CONNECT MRE DUC MWMR detects movement using a highly sensitive microwave detector and turn the load on. When an area is no longer occupied the load will switch off after an adjustable time out period. This microwave works by emitting low power microwave signals and measuring the reflections as the signals bounce off moving objects.

The detector also has an integral light sensor which can provide the following optional features:-

- With Connect dimming marshalling boxes, the unit can provide a maintained illuminance (or daylight linking) feature. The internal light sensor measures the light level in an area and will automatically adjust the output of the luminaries, via the marshalling box, to maintain a constant, adjustable lux level. Please note that this function only works with Connect dimming marshalling boxes using either DALI, DSI or analogue (1-10V) dimming ballasts.
- “Lux hold off” with non-dimming marshalling boxes, to prevent lighting coming on when a person first enters the area if there is sufficient ambient light present (only available using the SWITCHLITE IR PROGRAMMER programming handset - please see below).
- “Lux switch off” with non-dimming marshalling boxes, to switch lighting off during occupancy if the light level rises above a certain lux level in an area, which is sometimes required if ambient light affects the area during certain times of the day (only available using the SWITCHLITE IR PROGRAMMER programming handset - please see below).

When the unit is first powered up the microwave sensor will always detect immediately regardless of whether the room is occupied or not.

An integral IR sensor in the unit allows the additional functions to be used in conjunction with :-

Programming Handset (Part No. SWITCHLITE IR PROGRAMMER) the following additional functionality is available for commissioning purposes:-

- Setting the time delay.
- Sensitivity (range) adjustment.
- Walk test LED - to check that the detector is picking up movement in the area.
- Set the maintained illuminance lux setting on dimming marshalling boxes.
- Set “lux hold off” and “lux switch off” levels on non-dimming marshalling boxes.

The SWITCHLITE IR PROGRAMMER programming handset should only be used by specifically trained personnel for commissioning purposes only.

3. Fixing & Wiring

1. Connect a Cat 5 (RJ45) patch lead from the back of the sensor to the relevant port on the Connect marshalling box. An additional RJ45 connector is provided to daisy chain sensors together when being used with non-dimming marshalling boxes.
2. The detector should be sited so that the occupants of the room fall inside the detection pattern shown in section 5.
3. The detector should be sited so that the occupants of the room fall inside the detection pattern shown in section 5, at a recommended ceiling height of 2.8m (note: the higher the sensor is installed the shorter the detection range will be).
4. Sites as far away as possible from any lighting or ventilation equipment.
5. Do not fix to a vibrating surface.
6. Do not fix to a suspended luminaire.
7. Site as far away as possible from the surface of metal objects.
8. Mount using one of the two options overleaf.
9. Power the unit up - the load should come on immediately.
10. Vacate the room or remain very still and wait for the load to switch off (this should take no more than 2 minutes).
11. Check that the load switches on when movement is detected.
12. If required, adjust the sensitivity level down to reduce the range of detection.
13. *Using the SWITCHLITE IR PROGRAMMER programming handset - please refer to Section 4 (page 7 to 10) for setting the parameters.*

3. Fixing & Wiring (continued)

FLUSH FIXING

Warning - be careful bending springs when mounting unit.

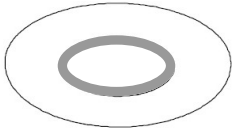

1

Hole Ø64mm

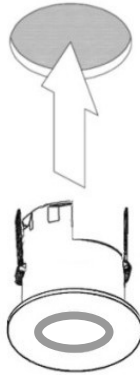

2

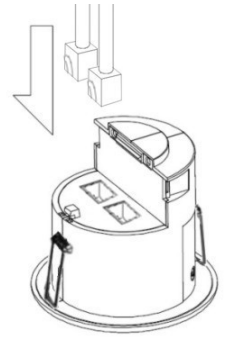

SURFACE FIXING

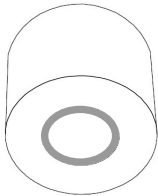

1

50mm or 60mm fixing centres

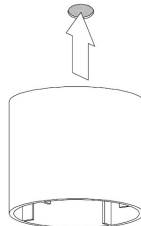

2

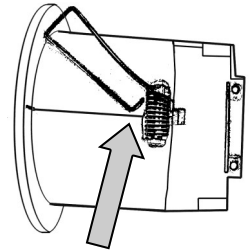

Pull out spring tab and rotate spring arm as shown

When mounting the detector:-

- Avoid direct sunlight entering the sensor.
- Do not site within 1m of forced air heating or ventilation.
- Do not site within 1m of any lighting.
- Do not fix to a vibrating surface.

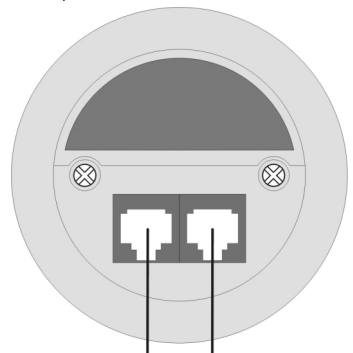

**2 x Connect RJ45 Connections
for Cat 5 patch leads**

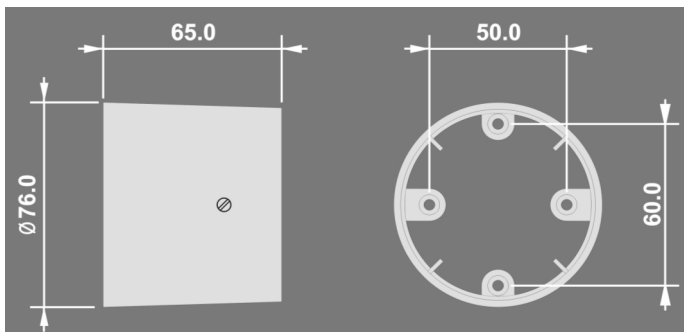
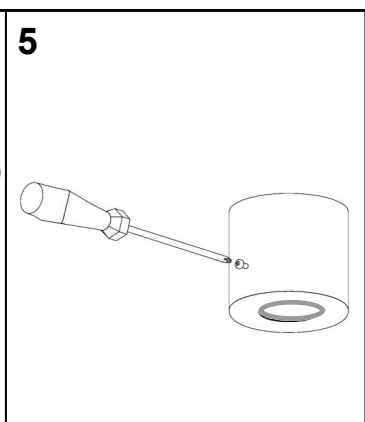
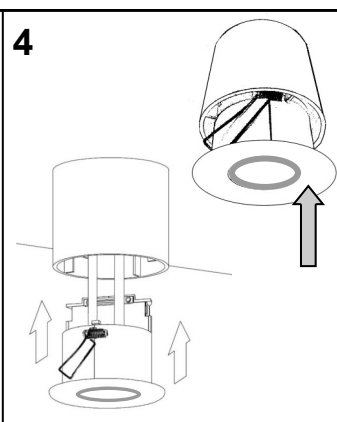
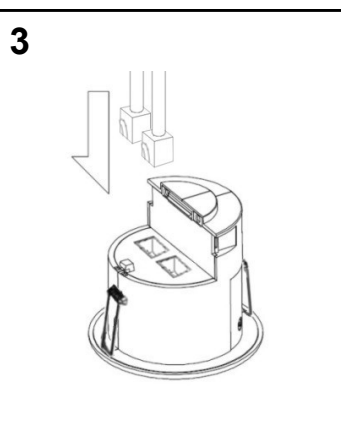
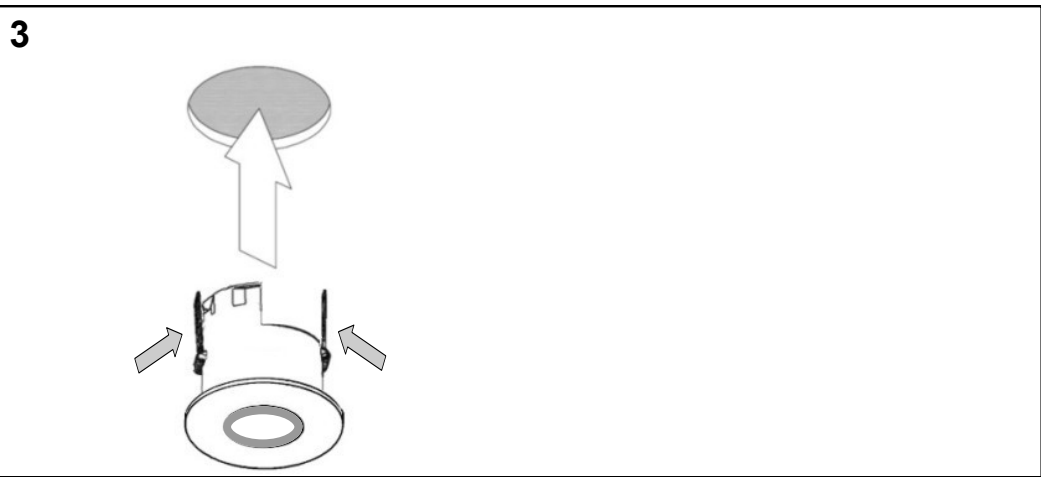

Surface Mount Backing Box
(Part No. 96239827)
(not supplied with detector)

4. Programming

Using the SWITCHLITE IR PROGRAMMER

All the following functions can be programmed using the remote control SWITCHLITE IR PROGRAMMER handset:

Please note that there are some parameters that appear on the SWITCHLITE IR PROGRAMMER handset which are not listed below—do not attempt to use these.

- Press the “on” button on the handset to switch the handset on.
- Select the menu using the left and right arrows and press “on”.
- Adjustments to each parameter can be made by using the up and down arrow keys on the handset.
- To send the selected command press the “on” button whilst pointing the handset at the detector lens. The red LED behind the detector lens will flash to show that the command has been received.
- To exit the menu, scroll right until “Previous menu” appears, then press “on”, which will take you back to the main menu headers, or alternatively press and hold the left key which will also take you back to the main menu headers.
- To switch the handset off, press and hold the left arrow key. On the main menu (“Detector Param” will show), scroll right until “Off” appears . Press the “on” button” to turn off. The handset will switch off automatically after a time period if left on.

4. Programming (continued)

Time Delay, Sensitivity & Walk Test functions

1. Go to “Detector Param” menu on the SWITCHLITE IR PROGRAMMER handset, and press “on”, then scroll left and right using the left and right arrow keys through the menu to see the following parameters.

(Factory default settings are shown in brackets):

- | | |
|-------------------------------|--------------------------------------------------------------------------------------------------------------------------------------------------------------------------------------------|
| 1.1 Time mins (20 min) | (Time delay adjustment) 10 seconds to 99 minutes time delay (select 0 for 10 second delay – use for commissioning only). |
| 1.2 Sens On (9) | Sensitivity level when the detector is already operational - adjustable between 1 (min.) and 9 (max.) |
| 1.3 Sens Off (9) | Sensitivity level for switching the detector on – adjustable between 1 (min.) and 9 (max.). |
| 1.4 Walk Test (N) | Select “Y” for “Yes” - to operate the function. An LED behind the detector lens will flash to show movement is being detected (use for commissioning only). Select “N” for “No” to cancel. |
| 1.5 Factory Default | Restores factory default settings. |

4. Programming (continued)

Using the SWITCHLITE IR PROGRAMMER

Non-Dimming Lux Switching functions

2. Lux switching on all channels covered by one sensor

Press and hold the left arrow key. On the main menu (“Detector Param” will be showing), scroll right until the “Ch1(sw) Set” menu appears on the SWITCHLITE IR PROGRAMMER handset, and press “on”, then scroll right until “Special” appears, and select it by pressing the “on” button.

(Factory default settings are shown in brackets):

- 2.1 Switch level on (199)** “Sw lev on” appears with 3 figures next to it; this is the lux level setting to prevent the luminaires being switched on if the ambient light level is sufficient (adjustable between 101 to 199). The luminaires will always be switched on at level 199 (maximum).
- 2.2 Switch level off (199)** Scroll right until “Sw lev off” appears with 3 figures next to it; this is the lux level setting to switch the luminaires off during occupancy if the ambient light level goes above the setting (adjustable between 101 to 199). At 199 the lights will be kept on regardless of ambient light level. This level must be set higher than the “Sw level on”, and it is recommended that it is a minimum of 10 levels higher to avoid nuisance switching.

3. Lux switching on Channel A only

- Scroll right on main menu until “Modes” appears, and select it by pressing the “on” button.
- “Channel modes” appears – select that by pressing the “on” button.
- Scroll right until “Sw&Dim separate” appears – send that command to the sensor by pointing the handset toward the sensor and pressing the “on” button at the same time.
- Press and hold the left arrow key – this takes you back to the “Detector Parameters)” menu.
- Scroll right until “Ch2(dim) Set” appears, and select it by pressing the “on” button.
- “Light lev(el)” appears with 3 figures (000 to 999 scale) next to it. Default is 999.
- Adjust this scale using the “up” and “down” arrows to select the lux switching level.
- Send the light level to the sensor by pointing the handset toward the sensor and pressing the “on” button at the same time.
- Re-adjust the light level if required to suit the lux switching level required.

4. Programming (continued) Using the SWITCHLITE IR PROGRAMMER

Dimming functions

4. Press and hold the left arrow key. On the main menu ("Detector Param" will be showing), scroll right until the "Ch2(dim) Set" menu appears on the SWITCHLITE IR PROGRAMMER handset, and press "on", then scroll left and right through the menu to see the following parameters:

(Factory default settings are shown in brackets):

- | | |
|------------------------------|-------------------------------------------------------------------------------------------------------------------------------------------------------------------------------------------------------------------------------------------|
| 4.1 Light level (999) | Maintained illuminance level (adjustable between 1 and 999). At 999 the output will be always be at maximum. |
| 4.2 Off value (99) | Always ensure that this is set to 99. |
| 4.3 Speed on (40) | Determines the dimming response speed after the setup time has finished. Measured in 0.1 sec intervals. |
| 4.4 Speed set (5) | Determines the dimming response speed during the set up time. Measured in 0.1 sec intervals. |
| 4.5 Set seconds (120) | Determines how long the dimming response set-up period lasts on power-up or on setting change (adjustable between 1 and 999 seconds). This enables the desired lux level to be achieved rapidly when the lights come on, or during setup. |

Dimming functions are continued on Page 10

4. Programming (continued)

Using the Programming Handset (Part No. SWITCHLITE IR)

User menu functions with dimming applications

5. Press and hold the left arrow key. On the main menu (“Detector Param” will be showing), scroll right until the “User” menu appears on the SWITCHLITE IR PROGRAMMER handset, and press “select”, then scroll left and right through the menu to see the following parameters:

- | | |
|-------------------------|------------------------------------------------------------------------------------------------------------------|
| 5.1 Lux up | Increase light level. Reverts when occupancy cycle complete. |
| 5.2 Lux down | Decrease light level. Reverts when occupancy cycle complete. |
| 5.3 Scene up | Steps up between 6 pre-defined scenes. |
| 5.4 Scene down | Steps down between 6 pre-defined scenes. |
| 5.5 Scene# | Select the individual scene, between 0 and 6.
(1 = min. output; 2 = 10%; 3 = 25%; 4 = 50%; 5 = 75%; 6 = 100%) |
| 5.6 Override on | Permanently overrides the luminaire output on. |
| 5.7 Override off | Permanently overrides the luminaire output off. |
| 5.8 Cancel | Cancels the on or off override, returning the detector to normal operation. |
| 5.9 Set | If sent before using Lux Up (5.1) or Lux Down (5.2), it will set the maintained light level as in 4.1. |

5. Detection Patterns

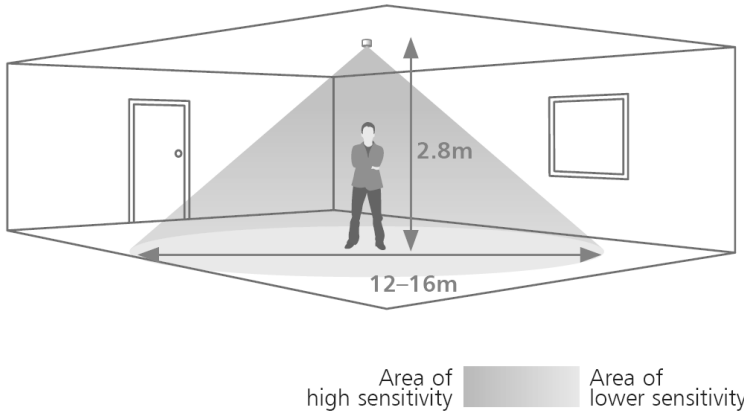

The above detection zone is available at maximum sensitivity.
If sensitivity is reduced, the range will also be reduced

6. Fault finding

LIGHTS DO NOT COME ON

- Check to see if the Connect marshalling box is powered up and the wiring is correct. Disconnect both RJ45 connections on the Cat 5 patch lead and re-connect, ensuring that they “click” into position, making good connection.
- Check that the “lux hold off” setting is not keeping the lights off because there is sufficient ambient light.
- If the detection range is smaller than expected, check the diagram above. Rotating the sensor slightly may improve the range.
- If the LED is flashing at regular intervals, this shows that the detector is being overridden. Press the cancel button on the handset.

LIGHTS DO NOT GO OFF

- Ensure that the area is left unoccupied for longer than the selected timer setting.
- Make sure that the sensor is not adjacent to circulating air, heaters or lamps and not on a vibrating surface or in the view of moving objects.
- If the LED is flashing at regular intervals, this shows that the detector is being overridden on. Press the cancel button on the handset.

7. Specification

LOAD

See datasheet for Connect marshalling box

SUPPLY VOLTAGE

12VDC

TIME OUT PERIOD

Adjustable 10 seconds to 99 minutes

LIGHT LEVEL

Light to dark

FIXING METHOD

Spring fixing, or surface fixing using additional Part No. DBB (Surface mounting box)

MATERIAL

Flame retardant ABS

TYPE

Class 2

FREQUENCY

5.8 GHz

SAFETY

The microwave radiation emitted by these units is extremely low power and complies with ANSI standard "IEEE95.1-1999 Standard for Safety Levels with Respect to Human Exposure to Radio Frequency Electromagnetic Fields 3kHz-300GHz"

TEMPERATURE

-10°C to 35°C

CONFORMITY

EMC-89/336/EEC 
LVD-73/23/EEC

IMPORTANT NOTICE!

This device should be installed by a qualified electrician in accordance with the latest edition of the IEE wiring regulations.

Due to our policy of continual product improvement Thorn reserves the right to alter the specification of this product without prior notice.

THORN

Thorn Lighting Ltd
Durhamgate
Spennymoor
Co Durham
DL16 6HL
United Kingdom
Tel: + 44 (0) 1388 420042
www.thornlighting.co.uk
technical@thornlighting.com

Ref #WD439 Issue 1